

Southern Staircase

Stairs ■ Stair Trim

IMPORTANT: READ ALL INSTRUCTIONS BEFORE BEGINNING

Stair Kit in a Box Fully Supported Adjustable Interior Box Stair Kit

For Stairs:

- Up to 43 1/2" finished width (sheetrock to sheetrock)
- Up to 124" floor to floor height
- Tread runs range from 9" to 9 1/2" (depending on rise)
- Simple & quick installation
- Tested by a certified testing laboratory
- SBCCI Listed
- Consistent rise and run throughout stair

NOTE: If your floor to floor height is less than 55", confirm that this system will work. This stair system will not work for applications with floor to floor heights in the following ranges: 0" to 13 1/2", 15 3/4" to 20 1/4", 23 1/4" to 27", 31 1/4" to 34", 39" to 40 3/4", 46 3/4" to 47 1/2" and 54 1/2".

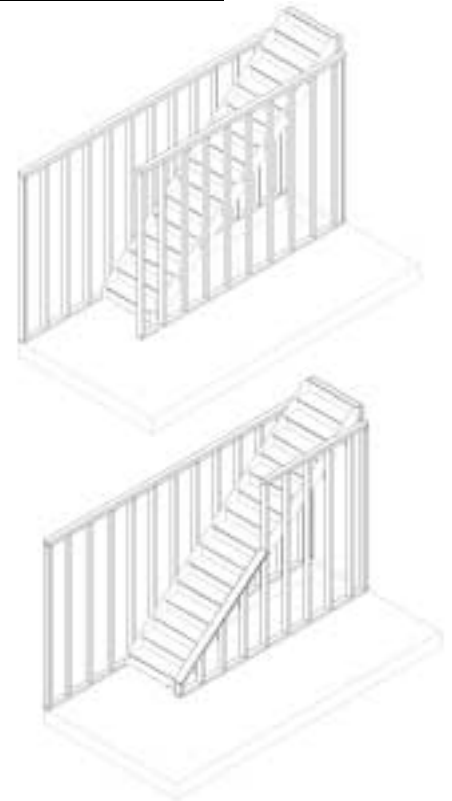

Code requirements vary throughout the country. Check local codes before installing this product.

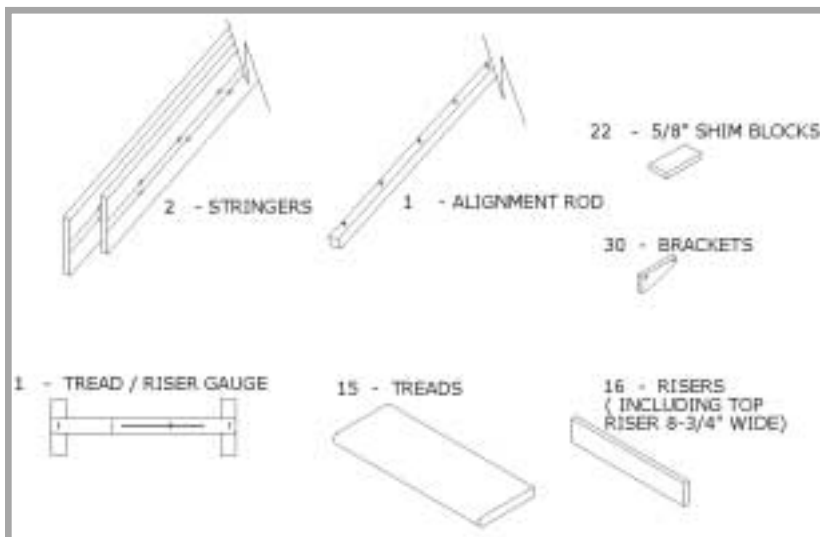

Tools Required

Hammer
Framing Square
Level
Plumb Bob
Tape Measure
Circular Saw
Table Saw
Caulking Gun
Nails – 5d, 8d, and 16d
Construction Grade Adhesive
Phillips Screwdriver

Stair Kit in a Box Installation Instructions

Step 1 Determine Finished Floor to Floor Dimension

Refer to **Fig. A** in the **Appendix A**. You will record the information derived below on the Stair Installation Worksheet.

Measure the Floor to Floor Dimension

Measure the distance from the bottom floor to the top floor as shown in **Fig. A**. Record this value on line 1 of worksheet.

Adjust For Finished Floor Thickness

If stair area is unfinished, the floor to floor will need to be adjusted by the thickness of the finished flooring on the bottom and top floor. (Examples of typical flooring allowances: carpet 1/4" to 3/4"; hardwood 1/4" to 3/4". Please note that allowances vary depending upon the materials you are using.) Record the bottom floor allowance on line 2 and the top floor allowance on line 3 of the worksheet. Record the stair allowance (the thickness of the carpet, if any, on the stair) on line 5. E.g.: 107 1/2" minus 3/4" (bottom floor allowance for hardwood flooring) plus 1/4" (top floor allowance for carpet) = 107".

Step 2 Determine Stair Rise and Run

Refer to **Appendix A (Stair Specification Chart)**.

Using the Stair Specification Chart, locate the finished floor to floor dimension closest to that value found on line 4 of the Stair Installation Worksheet. (Don't worry you will just be using one line on this chart!) This will give you the corresponding Tread run, Rise and Total Run. Record these values on lines 6, 7, and 8 of the Stair Installation Worksheet. Circle the color of your Total Rise dimension (either Red or Blue). There are two sets of color-coded holes on each stringer (Red and Blue). You will use the set selected above, but we'll get to that later.

If your stair system requires platforms, then refer to **Appendix B (Platform Worksheet)**.

Step 3 Confirm that Your Stair Will Fit in the Space Allowed

Refer to **Appendix C** Headroom Worksheet. This worksheet will lead you through the process of determining your headroom.

Then you will determine your bottom clearance (the distance from the end of your stair to the nearest obstruction or wall). See **Fig. A**. When calculating headroom, you marked the end of the stair. Now measure from this mark to the nearest obstruction. This is your bottom clearance. The minimum bottom clearance varies depending upon your local building code, but is typically 36". Check your local building code to determine the minimum bottom clearance allowed in your area.

Step 4 Install Tread and Riser Brackets

Each stringer is shipped in two pieces, and must be spliced together before assembling the stair. Place both sections of the left hand stringer face down on the floor. Apply construction adhesive to the area the splice covers, then insert the splice. (It will only fit one way to assure good alignment.) Then insert 6 wood screws through the splice into each stringer (12 screws total per splice). Repeat these steps for the right hand stringer.

Lay the stringers flat on the floor about 3' apart as shown in **Fig. B**. Position the stringers so the color-coded lines you selected on Line 9 of the worksheet are on the outside, and the bottom of both stringers are on the same end. (For Example: if you selected Red in Line 9, then the Red lines on each stringer should be on the outside).

Using the color selected in line 9, insert the appropriate number of tread and riser brackets (from Line 11 of worksheet) into the color coded holes of each stringer beginning at bottom. Brackets are marked left and right.

Place a framing square between two brackets as shown in **Fig. B** and rotate the brackets, so that they are positioned for the exact tread run (Line 6 of worksheet) and tread rise (line 7) as indicated. Fasten the first bracket to the stringer using four 5d nails. Place the alignment rod into the brackets beginning with the first bracket. Position the other brackets by placing the color-coded pins of the alignment rod into the brackets (See **Fig. C**). This will line up all of the brackets into the correct position, then nail them in place using four 5d nails each. If stair has more than 8 treads, move the alignment rod to the last fixed bracket and place the remaining loose brackets onto the alignment rod. Then nail the balance of the brackets to the stringer.

Repeat this process for the second stringer.

The alignment rod is only used for positioning the brackets. It is not needed anymore after this step has been completed.

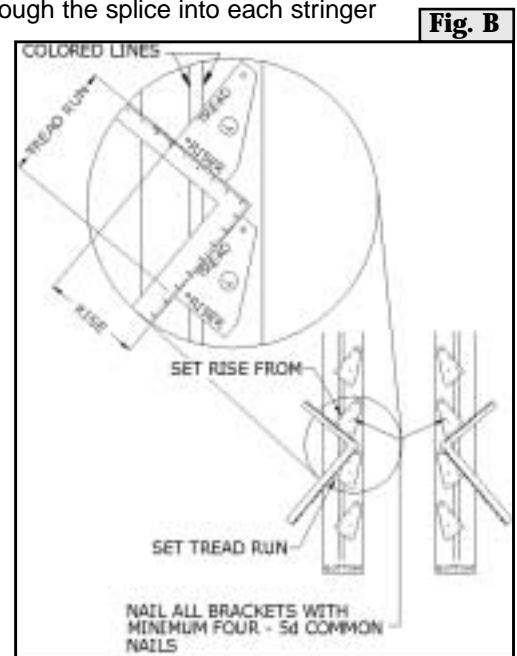

Step 5 Cut Bottom of Stringer

Begin by making the bottom stringer cuts on the right hand stringer. Then simply repeat the process for the left hand stringer. **Note:** The drawings in **Fig. D** are for the right hand stringer only.

The first cut is made parallel to the bottom riser, 4" from the front of the tread and riser bracket. Mark a line 4" from the riser face of the bracket, parallel to this face (See **Fig. D**). Make the first cut here. (See note below if you are tight on space.)

Use the following to determine where to make the second bottom cut:

Enter Rise (line 7 of worksheet)		_____
Plus Bottom Floor Allowance (line 2)	+	_____
Minus Stair Allowance (line 5)	-	_____
Minus Tread Thickness	-	_____ 1"
Equals Bottom Cut (2nd cut)	=	_____

The second cut is made under the first bracket, parallel to the top of the first bracket as shown in **Fig. D**.

Repeat this step for the left hand stringer.

Note: If you are tight on space at the bottom of the stair, then you can make the first stringer cut flush with the tread nosing to gain a little space. Determine the location of this cut as follows:

	_____ 11"
Minus Tread Run (Line 6 on Worksheet)	_____
Equals location of 1st stringer cut	_____

Then use this value to make the 1st stringer cut rather than 4" from the bottom bracket.

Step 6 Cut Top of Stringer

Again, make the top cuts for the right hand stringer first. Then repeat the process for the left hand stringer. **Note:** The drawings in **Fig. E** are for the right hand stringer only.

Position the framing square on the top bracket so that the corner is at the back of the top riser. This position is determined by measuring from the front of the bracket back the distance of the tread run (Line 6). Make the first cut parallel to the top riser as shown in **Fig. E**.

Use the following to determine the location of the second top stringer cut:

Enter Rise (line 7 of worksheet)		_____
Plus Stair Allowance (line 5)	+	_____
Plus Tread Thickness	+	_____ 1"
Minus Top Floor Allowance (line 3)	-	_____
Equals Top Cut (2nd cut)	=	_____

The second cut is made parallel to the top tread as shown in **Fig. E**.

Repeat step 6 for the left hand stringer.

Step 7 Fasten Stringers to Wall

The top cut of the stringer should be flush with the top floor, and the bottom of the stringer will rest on the bottom floor. Place the stringer in position against the wall. Check each stringer for levelness before nailing to the wall. This is done by placing a small level on a top edge of one of the brackets, while holding the stringer in place.

If you don't have sheetrock installed yet, place sheetrock shims (supplied with

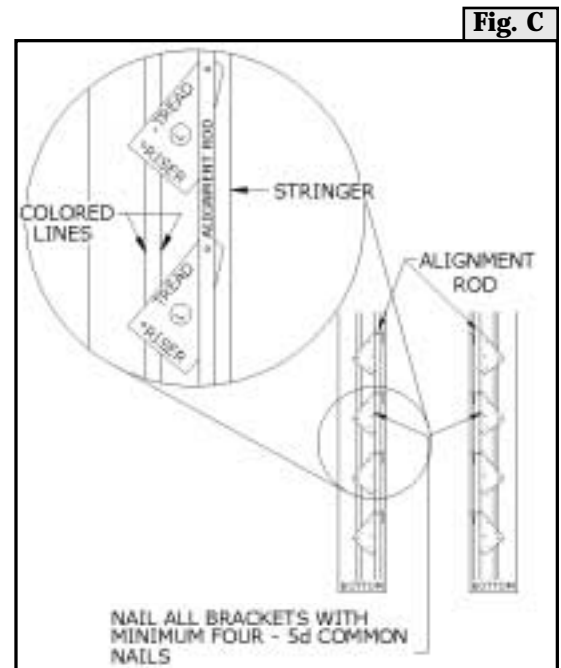

Fig. D

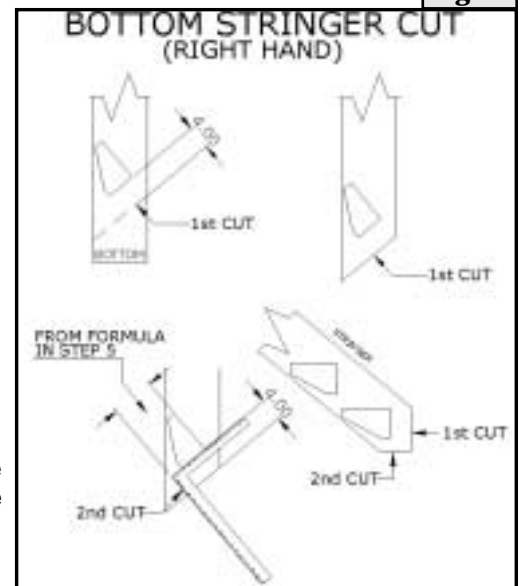
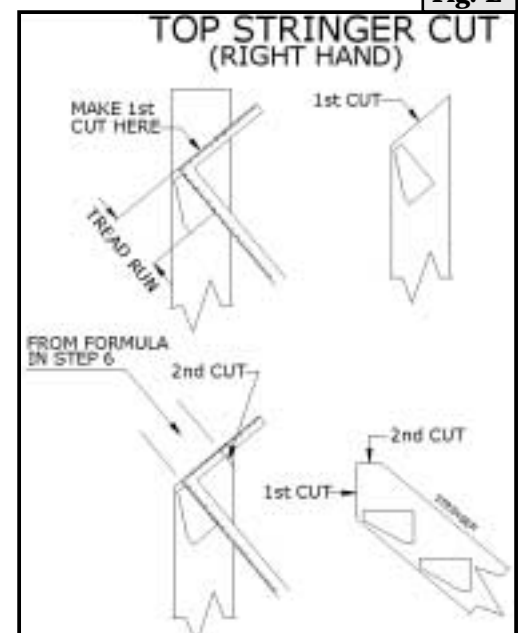

Fig. E



your Stair Kit in a Box) between the stringer and the stud (see **Fig. F**). Then nail through the stringer (and sheetrock shim), and into each stud. Use a minimum of two 16d casing nails per stud. Studs must be placed no more than 16" on center.

Note: The sheetrock shims provided with this kit are 5/8" thick. They are intended for use with 1/2" thick sheetrock. Custom shims are required for other sheetrock sizes. If you are installing this stair on a concrete slab, then you must place a vapor barrier between the bottom of the stringers and riser and the concrete slab.

Step 8 Install Treads and Risers

Measure the length of the bottom riser using the tread/riser gauge (see **Fig. G**). Lock the gauge in place and mark the 1st riser. Cut the first riser to this length. Next measure from the bottom floor to the top of the first bracket. Rip the bottom riser to this width. **NOTE:** This is the only riser that must be ripped. The other risers will extend below the bottom of the tread. Now measure the length of the 1st tread using the Tread/Riser Gauge. Then cut the 1st tread to this length.

Repeat this process for each riser and tread.

1. Place a bead of construction grade adhesive on the front of the bottom brackets.
2. Position the bottom riser in place, and nail the riser to both brackets using two 8d nails.
3. Glue and nail the next riser in place by setting the top of the riser flush with the top of the next brackets.
4. Place a bead of construction adhesive along the top of the brackets and the top edge of the lower riser. Then place a bead of construction adhesive along the back edge of the tread to be installed.
5. Then set the tread on top of the riser and brackets and push it up against the next riser.
6. Nail one 8d nail through the center of the tread into the riser. Then nail two 8d nails through the tread into each bracket (see **Fig. H**).
7. Then nail through the back of the upper riser into the back of the tread using 8d nails spaced a maximum of 6" apart (see **Fig. I**).
8. Cut the next tread and riser to length.
9. Then repeat this process until all but the top tread and riser are installed.

Fig. F

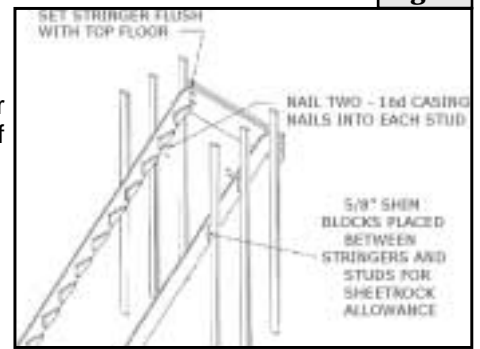

Fig. G

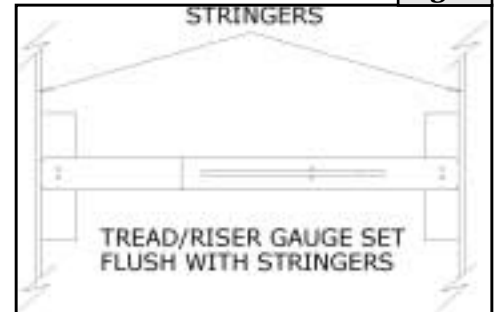

Fig. H

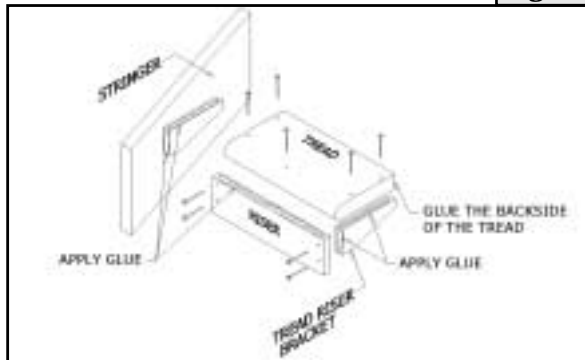
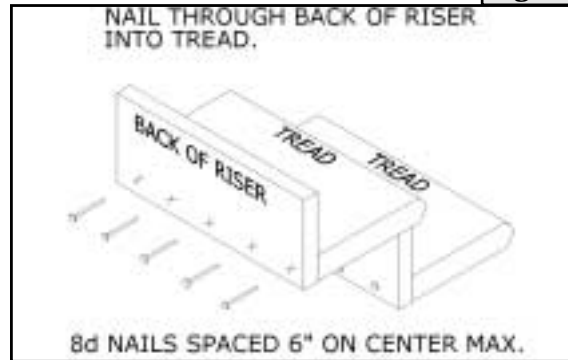

Fig. I



Step 9 Install the Top Tread and Riser

The top tread and riser will be installed in one assembly so the riser can be nailed to the tread properly.

1. Place the top tread on the top brackets. Hold the top riser in place with the top edge flush with the second floor.
2. Mark the location where the tread will be fastened to the riser.
3. Place a bead of glue on the back edge of the tread.
4. Locate the riser in the proper position on the tread and nail the riser to the tread using 8d nails a maximum of 6" apart as shown in **Fig. I**.
5. Apply glue to the top edge of the top brackets and the riser, and the back of the top riser. Then install this assembly in place on the top brackets.
6. Nail the top tread to the brackets, on riser as shown in **Fig. H**.
7. Nail the top riser to the header using a minimum of 6-8d nails.

Congratulations, you have completed installation of your Stair Kit in a Box!

Stair Installation Worksheet

Use the Stair Installation Worksheet, along with these instructions to determine Stair Specifications:

1. Floor to Floor Measurement _____
2. Bottom Floor Allowance minus - _____
 equals = _____
3. Top Floor Allowance plus + _____
4. Finished Floor to Floor equals = _____
5. Stair Allowance _____
6. Tread Run from Stair Specification Chart _____
7. Rise from Stair Specification Chart _____
8. Total Run from Stair Specification Chart _____
9. Color Coded Stringer Hole (circle one) Red Blue
10. Total Rises from Stair Specification Chart _____
11. Number of treads (line 10 minus 1) _____

Example

107-1/2"

3/4"

106-3/4"

3/4"

107-1/2"

1/4"

9-1/16"

7-11/16"

119-3/4"

(Red) Blue

14

13

Total Rise (Floor to Floor)	Tread Run	Rise	Total Run
14 Rise Stair			
105 1/4	9 3/16	7 1/2	121 5/16
105 1/2	9 3/16	7 9/16	121 3/16
105 3/4	9 3/16	7 9/16	121
106	9 3/16	7 9/16	120 13/16
106 1/4	9 1/8	7 5/8	120 5/8
106 1/2	9 1/8	7 5/8	120 7/16
106 3/4	9 1/8	7 5/8	120 1/4
107	9 1/8	7 5/8	120 1/8
107 1/4	9 1/16	7 11/16	119 7/8
107 1/2	9 1/16	7 11/16	119 3/4
107 3/4	9 1/16	7 11/16	119 9/16
108	9	7 11/16	119 3/8
108 1/4	9	7 3/4	119 3/16
108 1/2	9	7 3/4	119
15 Rise Stair			
108 3/4	9 3/16	7 1/4	130 5/8
109	9 3/16	7 1/4	130 7/16
109 1/4	9 3/16	7 1/4	130 5/16
109 1/2	9 3/16	7 5/16	130 1/8
109 3/4	9 1/8	7 5/16	129 15/16
110	9 1/8	7 5/16	129 3/4
110 1/4	9 1/8	7 3/8	129 5/8
110 1/2	9 1/8	7 3/8	129 7/16
110 3/4	9 1/8	7 3/8	129 1/4
111	9 1/16	7 7/16	129 1/16
111 1/4	9 1/16	7 7/16	128 7/8
111 1/2	9 1/16	7 7/16	128 3/4
111 3/4	9 1/16	7 7/16	128 9/16
112	9 1/16	7 7/16	128 3/8
112 1/4	9	7 1/2	128 3/16
112 1/2	9	7 1/2	128

TOP FLOOR ALLOWANCE =
FINISHED FLOORING TO BE
APPLIED.

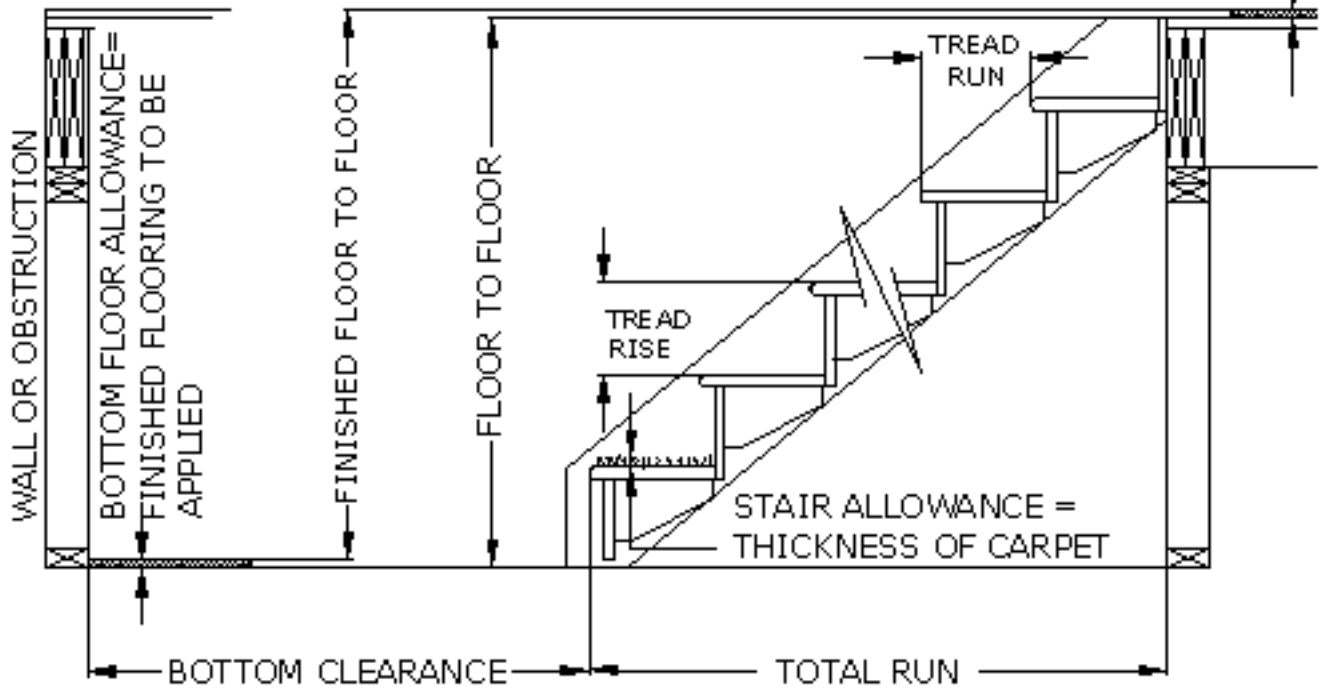

EXAMPLE

1/4" CARPET

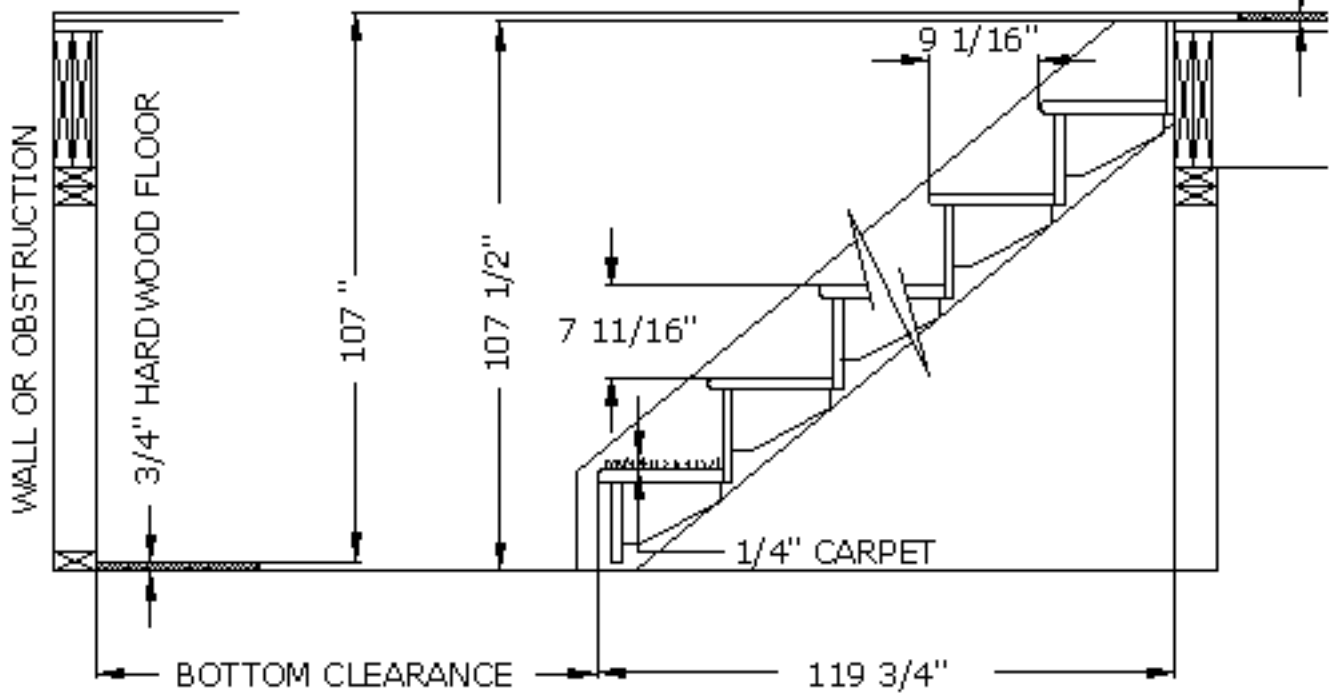

Stair Specification Chart

Total Rise (Floor to Floor)	Tread Run	Rise	Total Run	Total Rise (Floor to Floor)	Tread Run	Rise	Total Run	Total Rise (Floor to Floor)	Tread Run	Rise	Total Run			
2 Rise Stair				6 Rise Stair				8 Rise Stair						
13	3/4	9 1/2	6 7/8	11	41	3/4	9 3/8	6 15/16	48 11/16	59	1/4	9 1/16	7 3/8	65 7/16
14		9 3/8	7	11	42		9 3/8	7	48 9/16	59	1/2	9 1/16	7 7/16	65 5/16
14	1/4	9 5/16	7 1/8	11	42	1/4	9 3/8	7 1/16	48 7/16	59	3/4	9	7 7/16	65 3/16
14	1/2	9 3/16	7 1/4	11	42	1/2	9 5/16	7 1/16	48 5/16	60		9	7 1/2	65
14	3/4	9 1/8	7 3/8	11	42	3/4	9 5/16	7 1/8	48 3/16	8 Rise Stair				
15		9	7 1/2	11	43		9 1/4	7 3/16	48 1/16	60	1/4	9 3/16	7 1/2	66 1/8
2 Rise Stair				6 Rise Stair				8 Rise Stair						
15	1/4	9 1/8	7 5/8	11	43	1/2	9 3/16	7 1/4	47 13/16	60	1/2	9 3/16	7 7/16	65 15/16
15	1/2	9	7 3/4	11	43	3/4	9 3/16	7 5/16	47 11/16	60	3/4	9 1/8	7 5/8	65 13/16
3 Rise Stair				6 Rise Stair				8 Rise Stair						
20	1/2	9 1/2	6 13/16	20 1/2	44		9 1/8	7 5/16	47 9/16	61		9 1/8	7 5/8	65 5/8
20	3/4	9 7/16	6 15/16	20 7/16	44	1/4	9 1/8	7 3/8	47 7/16	61	1/4	9 1/16	7 11/16	65 1/2
21		9 3/8	7	20 3/8	44	1/2	9 1/16	7 7/16	47 5/16	61	1/2	9 1/16	7 11/16	65 5/16
21	1/4	9 5/16	7 1/16	20 5/16	44	3/4	9 1/16	7 7/16	47 1/8	61	3/4	9	7 11/16	65 3/16
21	1/2	9 1/4	7 3/16	20 1/4	45		9	7 1/2	47	62		9	7 3/4	65
21	3/4	9 3/16	7 1/4	20 3/16	6 Rise Stair				9 Rise Stair					
22		9 1/8	7 5/16	20 1/8	45	1/4	9 3/16	7 9/16	47 11/16	62	1/4	9 7/16	6 15/16	77 3/16
22	1/4	9 1/16	7 7/16	20 1/16	45	1/2	9 1/8	7 9/16	52 9/16	62	1/2	9 7/16	6 15/16	77 1/16
22	1/2	9	7 1/2	20	45	3/4	9 1/8	7 5/8	47 7/16	62	3/4	9 7/16	7	76 15/16
3 Rise Stair				7 Rise Stair				9 Rise Stair						
22	3/4	9 1/8	7 9/16	20 1/8	46		9 1/16	7 11/16	47 5/16	63		9 3/8	7	76 3/4
23		9	7 11/16	20	46	1/4	9 1/16	7 11/16	47 1/8	63	1/4	9 3/8	7	76 5/8
4 Rise Stair				7 Rise Stair				9 Rise Stair						
27	1/4	9 1/2	6 13/16	30 1/16	46	1/2	9	7 3/4	47	63	1/2	9 3/8	7 1/16	76 1/2
27	1/2	9 1/2	6 7/8	30	47	3/4	9 1/2	6 13/16	58 5/8	63	3/4	9 5/16	7 1/16	76 5/16
27	3/4	9 7/16	6 15/16	29 7/8	48		9 1/2	6 7/8	58 1/2	64		9 5/16	7 1/8	76 3/16
28		9 3/8	7	29 13/16	48	1/4	9 1/2	6 7/8	58 3/8	64	1/4	9 5/16	7 1/8	76
28	1/4	9 3/8	7 1/16	29 11/16	48	1/2	9 7/16	6 15/16	58 1/4	64	1/2	9 1/4	7 3/16	75 7/8
28	1/2	9 5/16	7 1/8	29 5/8	48	3/4	9 7/16	6 15/16	58 1/8	64	3/4	9 1/4	7 3/16	75 3/4
28	3/4	9 1/4	7 3/16	29 1/2	49		9 3/8	7	58	65		9 1/4	7 1/4	75 9/16
29		9 3/16	7 1/4	29 3/8	49	1/4	9 3/8	7 1/16	57 13/16	65	1/4	9 3/16	7 1/4	75 7/16
29	1/4	9 3/16	7 5/16	29 5/16	49	1/2	9 5/16	7 1/16	57 11/16	65	1/2	9 3/16	7 1/4	75 1/4
29	1/2	9 1/8	7 3/8	29 3/16	49	3/4	9 5/16	7 1/8	57 9/16	65	3/4	9 3/16	7 5/16	75 1/8
29	3/4	9 1/16	7 7/16	29 1/8	50		9 5/16	7 1/8	57 7/16	66		9 1/8	7 3/8	74 15/16
30		9	7 1/2	29	50	1/4	9 1/4	7 3/16	57 5/16	66	1/4	9 1/8	7 3/8	74 13/16
4 Rise Stair				7 Rise Stair				9 Rise Stair						
30	1/4	9 3/19	7 9/16	29 5/16	50	1/2	9 1/4	7 3/16	57 3/16	66	1/2	9 1/8	7 3/8	74 5/8
30	1/2	9 1/8	7 5/8	29 3/16	50	3/4	9 3/16	7 1/4	57	66	3/4	9 1/16	7 7/16	74 1/2
30	3/4	9 1/16	7 11/16	29 1/8	51		9 3/16	7 5/16	56 7/8	67		9 1/16	7 7/16	74 5/16
31		9	7 3/4	29	51	1/4	9 3/16	7 5/16	56 3/4	67	1/4	9	7 1/2	74 3/16
5 Rise Stair				7 Rise Stair				9 Rise Stair						
34	1/4	9 1/2	6 13/16	39 1/2	51	1/2	9 1/8	7 3/8	56 5/8	67	1/2	9	7 1/2	74
34	1/2	9 1/2	6 7/8	39 3/8	51	3/4	9 1/8	7 3/8	56 7/16	67	3/4	9 3/16	7 1/2	75 5/16
34	3/4	9 7/16	6 15/16	39 5/16	52		9 1/16	7 7/16	56 5/16	68		9 3/16	7 9/16	75 3/16
35		9 3/8	7	39 3/16	52	1/4	9	7 7/16	56 3/16	68	1/4	9 1/8	7 9/16	75
35	1/4	9 3/8	7 1/16	39 1/16	52	1/2	9	7 1/2	56	68	1/2	9 1/8	7 5/8	74 13/16
35	1/2	9 5/16	7 1/8	38 15/16	7 Rise Stair				9 Rise Stair					
35	3/4	9 1/4	7 3/16	38 13/16	52	3/4	9 3/16	7 9/16	56 7/8	68	3/4	9 1/8	7 5/8	74 11/16
36		9 1/4	7 3/16	38 3/4	53		9 3/16	7 9/16	56 3/4	69		9 1/16	7 11/16	74 1/2
36	1/4	9 3/16	7 1/4	38 5/8	53	1/4	9 1/8	7 5/8	56 5/8	69	1/4	9 1/16	7 11/16	74 5/16
36	1/2	9 3/16	7 5/16	38 1/2	53	1/2	9 1/8	7 5/8	56 7/16	69	1/2	9	7 3/4	74 3/16
36	3/4	9 1/8	7 3/8	38 3/8	53	3/4	9 1/16	7 11/16	56 7/16	69	3/4	9	7 3/4	74
37		9 1/16	7 3/8	38 1/4	54		9	7 11/16	56 3/16	10 Rise Stair				
37	1/4	9 1/16	7 7/16	38 1/8	54	1/4	9	7 3/4	56	70		9 3/8	7	86 3/16
37	1/2	9	7 1/2	38	8 Rise Stair				70	1/4	9 3/8	7	86	
5 Rise Stair				8 Rise Stair				10 Rise Stair						
37	3/4	9 3/16	7 9/16	38 1/2	54	3/4	9 1/2	6 13/16	68 1/16	70	1/2	9 3/8	7 1/16	85 13/16
38		9 1/8	7 5/8	38 3/8	55		9 1/2	6 7/8	67 15/16	70	3/4	9 5/16	7 1/16	85 11/16
38	1/4	9 1/8	7 5/8	38 1/4	55	1/4	9 7/16	6 7/8	67 3/4	71		9 5/16	7 1/8	85 9/16
38	1/2	9 1/16	7 11/16	38 1/8	55	1/2	9 7/16	6 15/16	67 5/8	71	1/4	9 5/16	7 1/8	85 3/8
38	3/4	9	7 3/4	38	55	3/4	9 7/16	6 15/16	67 1/2	71	1/2	9 5/16	7 1/8	85 1/4
6 Rise Stair				8 Rise Stair				10 Rise Stair						
41		9 1/2	6 13/16	49 1/16	56		9 3/8	7	67 3/8	71	3/4	9 1/4	7 3/16	85 1/8
41	1/4	9 1/2	6 7/8	48 15/16	56	1/4	9 3/8	7	67 1/4	72		9 1/4	7 3/16	84 15/16
41	1/2	9 7/16	6 15/16	48 13/16	56	1/2	9 3/8	7 1/16	67 1/16	72	1/4	9 3/16	7 1/4	84 13/16
6 Rise Stair				8 Rise Stair				10 Rise Stair						
41		9 1/2	6 13/16	49 1/16	56	3/4	9 5/16	7 1/8	66 15/16	72	1/2	9 3/16	7 1/4	84 5/8
41	1/4	9 1/2	6 7/8	48 15/16	57		9 5/16	7 1/8	66 13/16	72	3/4	9 3/16	7 1/4	84 7/16
41	1/2	9 7/16	6 15/16	48 13/16	57	1/4	9 1/4	7 3/16	66 11/16	73		9 3/16	7 5/16	84 5/16
6 Rise Stair				8 Rise Stair				10 Rise Stair						
41		9 1/2	6 13/16	49 1/16	57	1/2	9 1/4	7 3/16	66 1/2	73	1/4	9 1/8	7 5/16	84 1/8
41	1/4	9 1/2	6 7/8	48 15/16	57	3/4	9 1/4	7 1/4	66 3/8	73	1/2	9 1/8	7 3/8	84
41	1/2	9 7/16	6 15/16	48 13/16	58		9 3/16	7 1/4	66 1/4	73	3/4	9 1/8	7 3/8	83 13/16
6 Rise Stair				8 Rise Stair				10 Rise Stair						
41		9 1/2	6 13/16	49 1/16	58	1/4	9 3/16	7 1/4	66 1/16	74		9 1/16	7 3/8	83 11/16
41	1/4	9 1/2	6 7/8	48 15/16	58	1/2	9 3/16	7 5/16	65 15/16	74	1/4	9 1/16	7 7/16	83 1/2
41	1/2	9 7/16	6 15/16	48 13/16	58	3/4	9 1/8	7 5/16	65 3/4	74	1/2	9 1/16	7 7/16	83 5/16
6 Rise Stair				8 Rise Stair				10 Rise Stair						
41		9 1/2	6 13/16	49 1/16	59		9 1/8	7 3/8	65 5/8	74	3/4	9	7 1/2	83 3/16
41	1/4	9 1/2	6 7/8	48 15/16	8 Rise Stair				75		9	7 1/2	83	
41	1/2	9 7/16	6 15/16	48 13/16	59	1/4	9 1/8	7 3/8	65 5/8	10 Rise Stair				
6 Rise Stair				8 Rise Stair				10 Rise Stair						
41		9 1/2	6 13/16	49 1/16	59	1/2	9 1/8	7 3/8	65 5/8	75		9	7 1/2	83
41	1/4	9 1/2	6 7/8	48 15/16	8 Rise Stair				10 Rise Stair					
41	1/2	9 7/16	6 15/16	48 13/16	59	3/4	9 1/8	7 3/8	65 5/8	75	1/4	9	7 1/2	83

Stair Specification Chart

Total Rise (Floor to Floor)	Tread Run	Rise	Total Run
10 Rise Stair			
75 1/4	9 3/16	7 1/2	84 1/2
75 1/2	9 3/16	7 9/16	84 3/8
75 3/4	9 3/16	7 9/16	84 3/16
76	9 1/8	7 5/8	84
76 1/4	9 1/8	7 5/8	83 13/16
76 1/2	9 1/8	7 11/16	83 11/16
76 3/4	9 1/16	7 11/16	83 1/2
77	9 1/16	7 11/16	83 5/16
77 1/4	9	7 3/4	83 3/16
77 1/2	9	7 3/4	83

Total Rise (Floor to Floor)	Tread Run	Rise	Total Run
11 Rise Stair			
77 3/4	9 5/16	7 1/16	95 1/8
78	9 5/16	7 1/8	94 15/16
78 1/4	9 5/16	7 1/8	94 3/4
78 1/2	9 1/4	7 1/8	94 5/8
78 3/4	9 1/4	7 3/16	94 7/16
79	9 1/4	7 3/16	94 5/16
79 1/4	9 1/4	7 3/16	94 1/8
79 1/2	9 1/4	7 1/4	94
79 3/4	9 3/16	7 1/4	93 13/16
80	9 3/16	7 1/4	93 11/16
80 1/4	9 3/16	7 5/16	93 1/2
80 1/2	9 3/16	7 5/16	93 5/16
80 3/4	9 1/8	7 5/16	93 3/16
81	9 1/8	7 3/8	93
81 1/4	9 1/8	7 3/8	92 13/16
81 1/2	9 1/16	7 3/8	92 11/16
81 3/4	9 1/16	7 7/16	92 1/2
82	9 1/16	7 7/16	92 5/16
82 1/4	9	7 1/2	92 3/16
82 1/2	9	7 1/2	92

Total Rise (Floor to Floor)	Tread Run	Rise	Total Run
11 Rise Stair			
82 3/4	9 3/16	7 1/2	93 3/4
83	9 3/16	7 9/16	93 9/16
83 1/4	9 3/16	7 9/16	93 3/8
83 1/2	9 1/8	7 5/8	93 5/16
83 3/4	9 1/8	7 5/8	93 1/16
84	9 1/8	7 5/8	92 7/8
84 1/4	9 1/16	7 11/16	92 11/16
84 1/2	9 1/16	7 11/16	92 1/2
84 3/4	9 1/16	7 11/16	92 3/8
85	9	7 3/4	92 3/16
85 1/4	9	7 3/4	92

Total Rise (Floor to Floor)	Tread Run	Rise	Total Run
12 Rise Stair			
85 1/2	9 5/16	7 1/8	104 1/8
85 3/4	9 5/16	7 1/8	103 13/16
86	9 1/4	7 3/16	103 11/16
86 1/4	9 1/4	7 3/16	103 1/2
86 1/2	9 1/4	7 3/16	103 3/8
86 3/4	9 1/4	7 1/4	103 3/16
87	9 3/16	7 1/4	103
87 1/4	9 3/16	7 1/4	102 7/8
87 1/2	9 3/16	7 5/16	102 11/16
87 3/4	9 3/16	7 5/16	102 1/2
88	9 1/8	7 5/16	102 3/8
88 1/4	9 1/8	7 3/8	102 3/16
88 1/2	9 1/8	7 3/8	102
88 3/4	9 1/8	7 3/8	101 7/8
89	9 1/16	7 7/16	101 11/16
89 1/4	9 1/16	7 7/16	101 1/2
89 1/2	9	7 7/16	101 3/8
89 3/4	9	7 1/2	101 3/16
90	9	7 1/2	101

Total Rise (Floor to Floor)	Tread Run	Rise	Total Run
12 Rise Stair			
90 1/4	9 3/16	7 1/2	102 15/16
90 1/2	9 3/16	7 9/16	102 3/4
90 3/4	9 3/16	7 9/16	102 9/16
91	9 1/8	7 9/16	102 3/8
91 1/4	9 1/8	7 5/8	102 1/4
91 1/2	9 1/8	7 5/8	102 1/16

Total Rise (Floor to Floor)	Tread Run	Rise	Total Run
12 Rise Stair			
91 3/4	9 1/8	7 11/16	101 7/8
92	9 1/16	7 11/16	101 11/16
92 1/4	9 1/16	7 11/16	101 1/2
92 1/2	9 1/16	7 11/16	101 3/8
92 3/4	9	7 3/4	101 3/16
93	9	7 3/4	101

Total Rise (Floor to Floor)	Tread Run	Rise	Total Run
13 Rise Stair			
93 1/4	9 1/4	7 3/16	112 7/8
93 1/2	9 1/4	7 3/16	112 3/4
93 3/4	9 1/4	7 3/16	112 9/16
94	9 1/4	7 1/4	112 3/8
94 1/4	9 3/16	7 1/4	112 1/4
94 1/2	9 3/16	7 1/4	112 1/16
94 3/4	9 3/16	7 5/16	111 7/8
95	9 3/16	7 5/16	111 3/4
95 1/4	9 1/8	7 5/16	111 9/16
95 1/2	9 1/8	7 3/8	111 3/8
95 3/4	9 1/8	7 3/8	111 1/4
96	9 1/8	7 3/8	111 1/16
96 1/4	9 1/8	7 3/8	110 7/8
96 1/2	9 1/16	7 7/16	110 11/16
96 3/4	9 1/16	7 7/16	110 1/2
97	9 1/16	7 7/16	110 3/8
97 1/4	9	7 1/2	110 3/16
97 1/2	9	7 1/2	110

Total Rise (Floor to Floor)	Tread Run	Rise	Total Run
13 Rise Stair			
97 3/4	9 3/16	7 1/2	112 1/8
98	9 3/16	7 9/16	111 5/16
98 1/4	9 3/16	7 9/16	111 3/4
98 1/2	9 3/16	7 9/16	111 5/8
98 3/4	9 1/8	7 5/8	111 7/16
99	9 1/8	7 5/8	111 1/4
99 1/4	9 1/8	7 5/8	111 1/8
99 1/2	9 1/16	7 11/16	110 7/8
99 3/4	9 1/16	7 11/16	110 3/4
100	9 1/16	7 11/16	110 9/16
100 1/4	9	7 11/16	110 3/8
100 1/2	9	7 3/4	110 3/16
100 3/4	9	7 3/4	110

Total Rise (Floor to Floor)	Tread Run	Rise	Total Run
14 Rise Stair			
101	9 1/4	7 3/16	121 3/4
101 1/4	9 1/4	7 1/4	121 5/8
101 1/2	9 3/16	7 1/4	121 9/16
101 3/4	9 3/16	7 1/4	121 1/4
102	9 3/16	7 5/16	121 1/8
102 1/4	9 3/16	7 5/16	120 15/16
102 1/2	9 3/16	7 5/16	120 3/4
102 3/4	9 1/8	7 5/16	120 9/16
103	9 1/8	7 3/8	120 3/8
103 1/4	9 1/8	7 3/8	120 1/4
103 1/2	9 1/8	7 3/8	120 1/16
103 3/4	9 1/16	7 7/16	119 7/8
104	9 1/16	7 7/16	119 11/16
104 1/4	9 1/16	7 7/16	119 1/2
104 1/2	9	7 7/16	119 3/8
104 3/4	9	7 1/2	119 3/16
105	9	7 1/2	119

Total Rise (Floor to Floor)	Tread Run	Rise	Total Run
14 Rise Stair			
105 1/4	9 3/16	7 1/2	121 5/16
105 1/2	9 3/16	7 9/16	121 3/16
105 3/4	9 3/16	7 9/16	121
106	9 3/16	7 9/16	120 13/16
106 1/4	9 1/8	7 5/8	120 5/8
106 1/2	9 1/8	7 5/8	120 7/16
106 3/4	9 1/8	7 5/8	120 1/4
107	9 1/8	7 5/8	120 1/8
107 1/4	9 1/16	7 11/16	119 7/8
107 1/2	9 1/16	7 11/16	119 3/4
107 3/4	9 1/16	7 11/16	119 9/16
108	9	7 11/16	119 3/8

Total Rise (Floor to Floor)	Tread Run	Rise	Total Run
14 Rise Stair			
108 1/4	9	7 3/4	119 3/16
108 1/2	9	7 3/4	119

Total Rise (Floor to Floor)	Tread Run	Rise	Total Run
15 Rise Stair			
108 3/4	9 3/16	7 1/4	130 5/8
109	9 3/16	7 1/4	130 7/16
109 1/4	9 3/16	7 1/4	130 5/16
109 1/2	9 3/16	7 5/16	130 1/8
109 3/4	9 1/8	7 5/16	129 15/16
110	9 1/8	7 5/16	129 3/4
110 1/4	9 1/8	7 3/8	129 5/8
110 1/2	9 1/8	7 3/8	129 7/16
110 3/4	9 1/8	7 3/8	129 1/4
111	9 1/16	7 7/16	129 1/16
111 1/4	9 1/16	7 7/16	128 7/8
111 1/2	9 1/16	7 7/16	128 3/4
111 3/4	9 1/16	7 7/16	128 9/16
112	9 1/16	7 7/16	128 3/8
112 1/4	9	7 1/2	128 3/16
112 1/2	9	7 1/2	128

Total Rise (Floor to Floor)	Tread Run	Rise	Total Run
15 Rise Stair			
112 3/4	9 3/16	7 1/2	130 9/16
113	9 3/16	7 1/2	130 3/8
113 1/4	9 3/16	7 9/16	130 3/16
113 1/2	9 3/16	7 9/16	130
113 3/4	9 1/8	7 9/16	129 13/16
114	9 1/8	7 5/8	129 11/16
114 1/4	9 1/8	7 5/8	129 1/2
114 1/2	9 1/8	7 5/8	129 5/16
114 3/4	9 1/8	7 11/16	129 1/8
115	9 1/16	7 11/16	128 15/16
115 1/4	9 1/16	7 11/16	128 3/4
115 1/2	9 1/16	7 11/16	128 9/16
115 3/4	9 1/16	7 11/16	128 3/8
116	9	7 3/4	128 3/16
116 1/4	9	7 3/4	128

Total Rise (Floor to Floor)	Tread Run	Rise	Total Run
16 Rise Stair			
116 1/2	9 3/16	7 1/4	139 1/2
116 3/4	9 3/16	7 5/16	139 5/16
117	9 3/16	7 5/16	139 1/8
117 1/4	9 1/8	7 5/16	138 15/16
117 1/2	9 1/8	7 5/16	138 11/16
117 3/4	9 1/8	7 3/8	138 5/8
118	9 1/8	7 3/8	138 7/16
118 1/4	9 1/8	7 3/8	138 1/4
118 1/2	9 1/16	7 3/8	138 1/8
118 3/4	9 1/16	7 7/16	137 7/8
119	9 1/16	7 7/16	137 3/4
119 1/4	9 1/16	7 7/16	137 9/16
119 1/2	9	7 7/16	137 3/8
119 3/4	9	7 1/2	137 3/16
120	9	7 1/2	137

Total Rise (Floor to Floor)	Tread Run	Rise	Total Run
16 Rise Stair			
120 1/4	9 3/16	7 1/2	139 3/4
120 1/2	9 3/16	7 1/2	139 9/16
120 3/4	9 3/16	7 9/16	139 3/8
121	9 3/16	7 9/16	139 3/16
121 1/4	9 3/16	7 9/16	139
121 1/2	9 1/8	7 9/16	138 7/8
121 3/4	9 1/8	7 5/8	138 11/16
122	9 1/8	7 5/8	138 1/2
122 1/4	9 1/8	7 5/8	138 5/16
122 1/2	9 1/16	7 11/16	138 1/8
122 3/4	9 1/16	7 11/16	137 15/16
123	9 1/16	7 11/16	137 3/4
123 1/4	9 1/16	7 11/16	137 9/16
123 1/2	9	7 11/16	137 3/8
123 3/4	9	7 3/4	137 3/16
124	9	7 3/4	137

Platform Worksheet

In order to determine the height of any platform(s), begin by transferring important data from the Stair Installation Worksheet to the Platform Worksheet. Then, complete the remainder of the Platform Worksheet.

Transfer the following data from the Stair Installation Worksheet

- 1. Bottom floor allowance (line 2 of Stair Installation Worksheet) _____
- 2. Finished Floor to Floor (line 4 of Stair Installation Worksheet) _____
- 3. Tread Run (line 6 of the Stair Installation Worksheet) _____
- 4. Rise (line 7 of the Stair Installation Worksheet) _____
- 5. Total Rises (line 10 of the Stair Installation Worksheet) _____

Complete this section for the first (upper) platform.

- 6. Header to corner dimension (**Fig. J**) _____
- 7. # of treads in upper flight (subtract 4" from line 6, then divide this number by line 3).
Round down to the nearest whole number _____
- 8. # of rises in upper flight (line 7 plus 1) _____
- 9. # of rises from upper platform to bottom floor (line 5 minus line 8) _____
- 10. Record the finished flooring allowance (if any) for your platform _____
- 11. Platform height from bottom floor (multiply line 9 times line 4, then add line 1 and subtract line 10.) _____

Complete this section if the stair system has two platforms. This will determine the height of the second (lower) platform.

- 12. Upper platform to corner dimension (see **Fig. K**) _____
- 13. # of treads in middle flight (subtract 4" from line 12, then divide this number by line 3).
Round down to the nearest whole number _____
- 14. # of rises in middle flight (line 13 plus 1) _____
- 15. # of rises from platform to bottom floor (line 5 minus line 8 minus line 14) _____
- 16. Platform height from bottom floor (multiply line 15 times line 4, then add line 1 and subtract line 10) _____

Now you will build and install the platforms. Be sure that the platform is large enough for the entire bottom edge of the stringer to rest on the platform (see **Fig. L**). Check your local building code for platform specifications.

Once the platforms have been installed, return to Step 3 of the instructions. You will build your stairs with the number of rises specified on the Platform Worksheet (lines 8 and 9 above for stairs with 1 platform, or lines 8, 14, and 15 for stairs with 2 platforms.), instead of the total number of rises on the Stair Installation Worksheet.

Fig. J

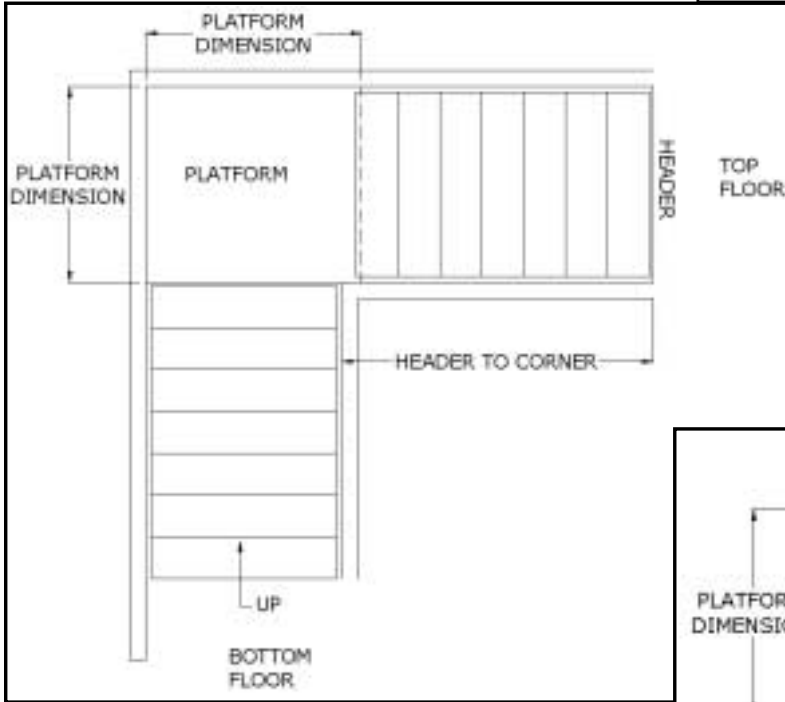
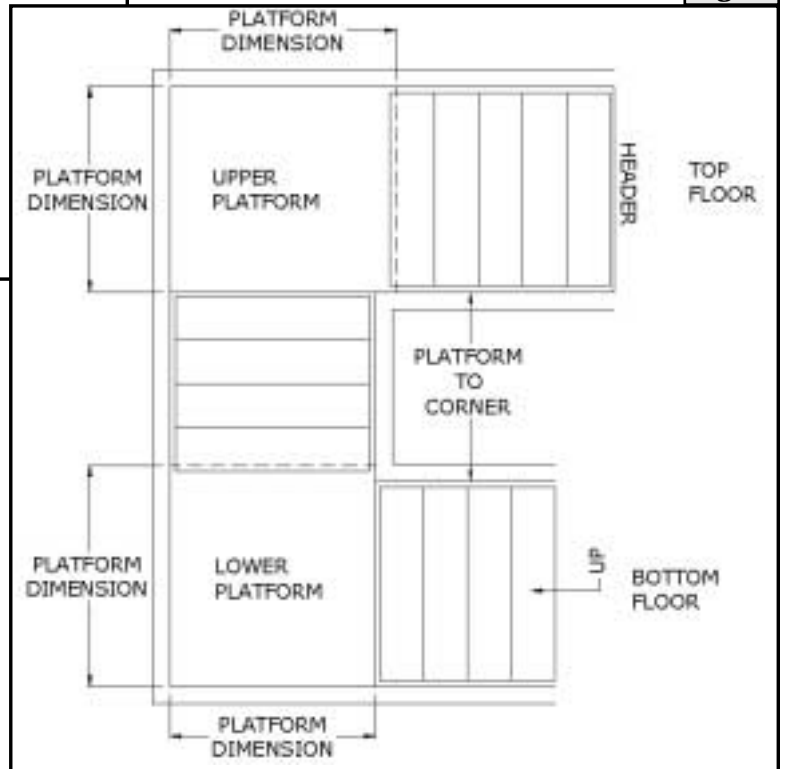
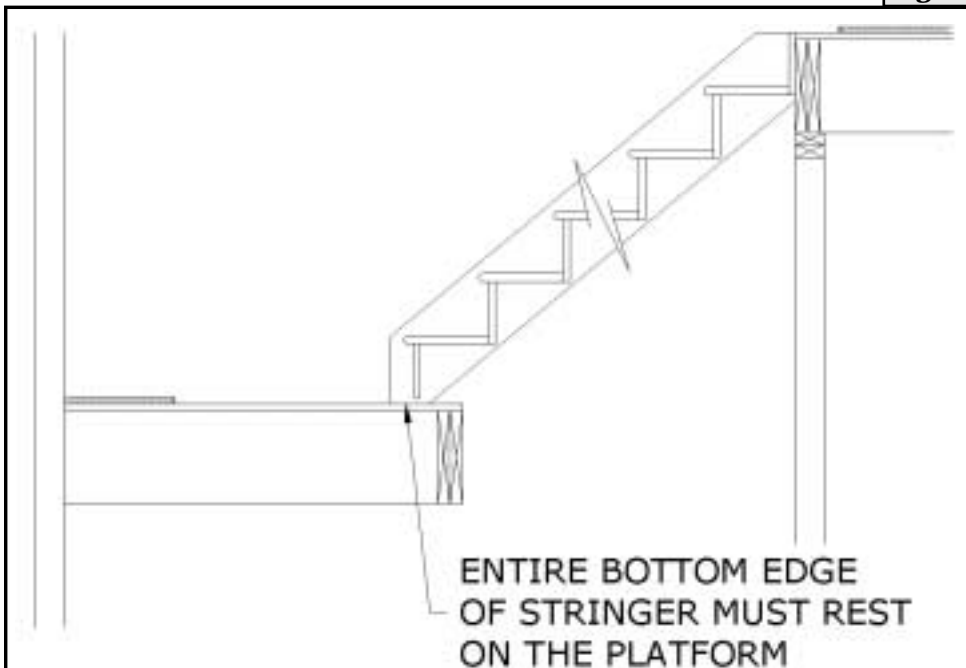

Fig. K



Note: All dimensions are framing to framing.

Fig. L



Headroom Worksheet

Before installing your Stair Kit in a Box stair, you must confirm that you have sufficient headroom. The minimum headroom allowed by most building codes is 80". Check your local building code to determine the minimum headroom allowed in your area.

This worksheet will assist you in determining headroom for a few basic scenarios, but it may not apply to your specific scenario. You must assure that you have sufficient headroom prior to installing your stair.

Complete the following worksheet to determine your headroom. (Refer to Fig. M.)

Transfer the following items from the Stair Installation Worksheet.

- 1. Bottom Floor Allowance (line 2 of Stair Installation Worksheet)
2. Tread Run (line 6 of Stair Installation Worksheet)
3. Rise (line 7 of Stair Installation Worksheet)
4. Total Run (line 8 of Stair Installation Worksheet)

Next, follow these steps to determine headroom.

- 5. Locate the headroom obstruction, and measure down from the bottom of the obstruction to the floor. (See Fig. M)
6. Plumb down from the front edge of the obstruction, and mark the floor.
7. Next, place a mark on the floor indicating the location of the end of your stair. If your stair does not have platforms, then measure from the header to the end of the stair (the dimension in line 4 above) and mark the floor.

If your stair does have platforms, then see Note below. Measure from the face of the lower platform the distance in line B and mark the floor.

- 8. Measure the distance between the marks in line 6 and line 7.
9. Determine the number of treads from the bottom of the stair to the obstruction (line 8 divided by line 2).
10. Determine the number of rises from the bottom of the stair to location of the obstruction (line 9 plus 1).
11. Determine the height of the stair at the location of the obstruction (multiply line 3 times line 10 then add line 1).
12. Calculate the headroom (line 5 minus line 11).

Note - Use this section if you have a platform. Complete the following steps to determine the length of the lower flight. A. Enter the number of treads in the lower flight (use line 7 of the Platform Worksheet if you have 1 platform, or line 14 of the Platform Worksheet if you have 2 platforms). B. Determine the length of the lower flight (line A times line 2, then add 3")

If you have less than 80" of headroom, then you must either move the obstruction, or cut back the header. See Fig. N for possible solutions. Move your header or obstruction about 1 1/2" from every 1" of additional headroom you need.

Fig. M

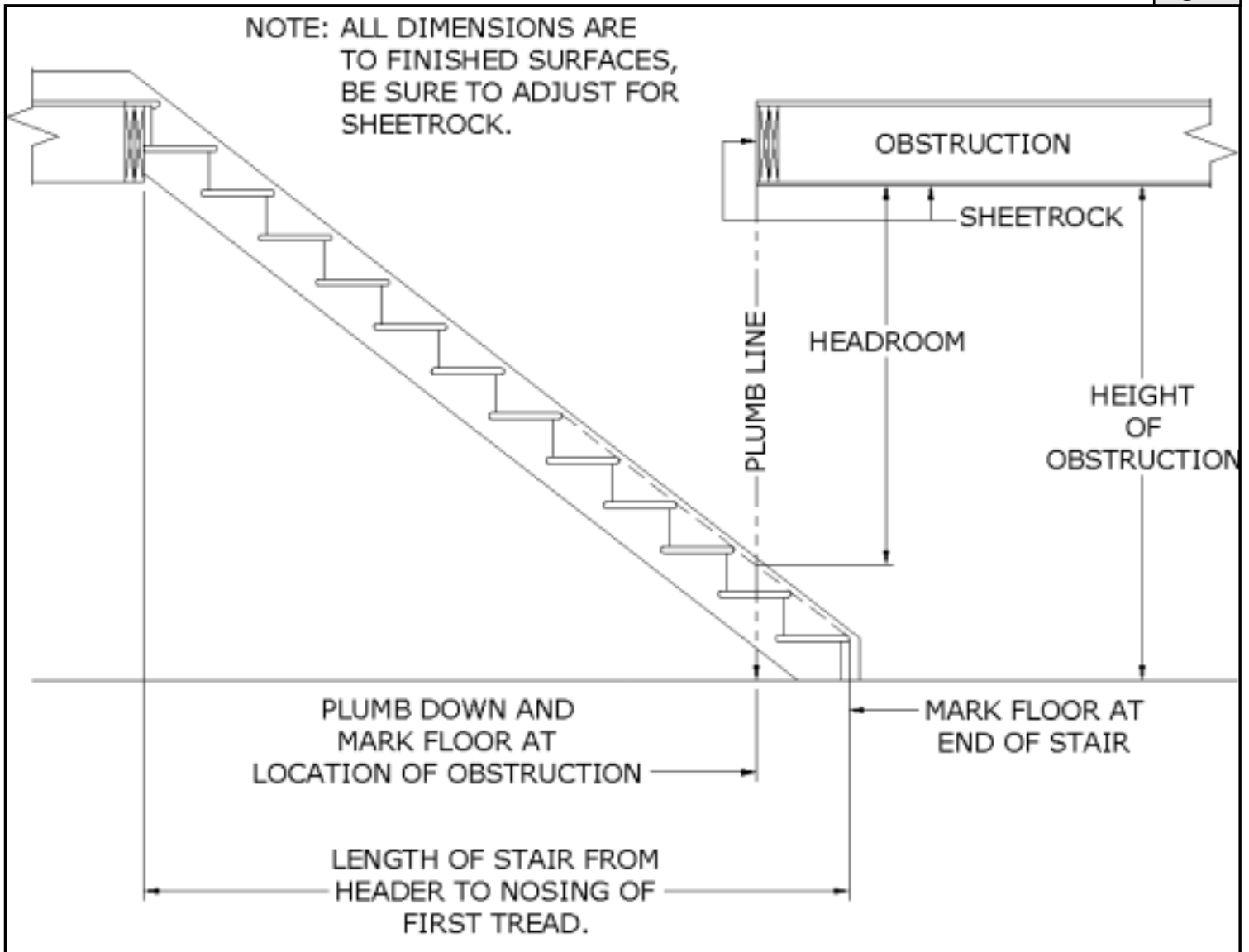

Fig. N

